

PAVEMENT

ADJUSTABLE 12" GATE BOX AND LID. SEE WDS-117. SEE NOTE 1.

12" POLYVINYL CHLORIDE PIPE

SPOT BRAZE

2" BRASS VALVE

6" OF CRUSHED ROCK TO SEAL OUT DIRT

10 1/2"

2 7/8"

2 3/8"

2"

3 1/4"

3"

12"

14"

2" BRASS PLUG

2" BRASS COUPLING

2" X 4" BRASS NIPPLE

2" BRASS STREET ELL

2" BRASS RISER AS REQUIRED

CONTINUED BELOW

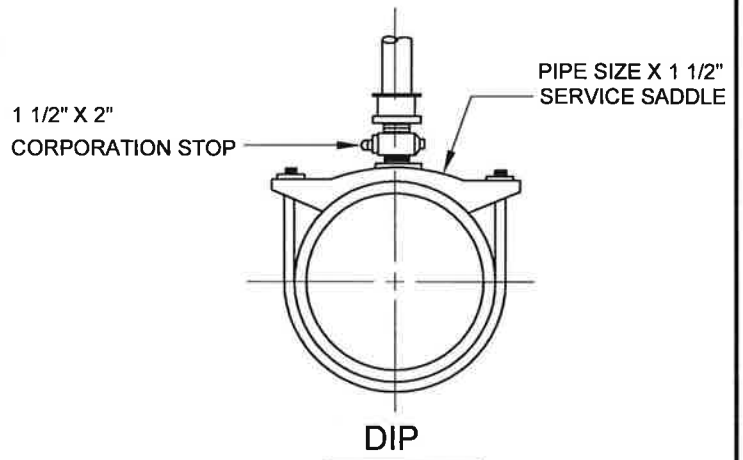
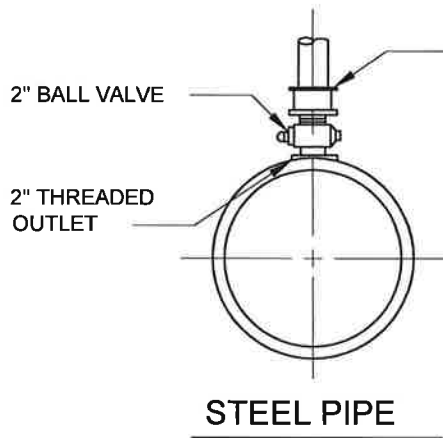

**NOTE:**

1. WHEN CHLORINATION, AIR RELIEF, OR BLOW-OFF IS NO LONGER REQUIRED THE GATE BOX, LID, RISER AND ASSEMBLY SHALL BE REMOVED LEAVING THE BRASS COUPLING AT THE CORPORATION STOP, WHICH WILL BE PLUGGED WITH A 2 INCH BRASS PLUG.

**TEMPORARY CHLORINATION, AIR RELIEF AND BLOW OFF ASSEMBLY**

**WDS -111**



**LONG BEACH  
WATER DEPARTMENT**

RECOMMEND

*Robert J. [Signature]*

DIVISION ENGINEER

APPROVED

*[Signature]*

DIRECTOR OF ENGINEERING

DATE: 11/11/14

SCALE: N.T.S.

SHEET 1 OF 1