

NOTE:

1. SUPPORT PIPE/BASE PLATE ASSEMBLY TO BE HOT DIP GALVANIZED (DOUBLE DIP) AFTER WELDING.
2. FLANGE SUPPORTS ARE NOT INTENDED FOR THRUST RESTRAINT.
3. CONTRACTOR CAN USE STAINLESS STEEL EPOXY WEDGE ANCHORS OR STAINLESS STEEL ANCHORS (INSTALLED POST-INSTALLATION) WITH DEPUTY INSPECTION IN LIEU OF "J" ANCHOR BOLTS.

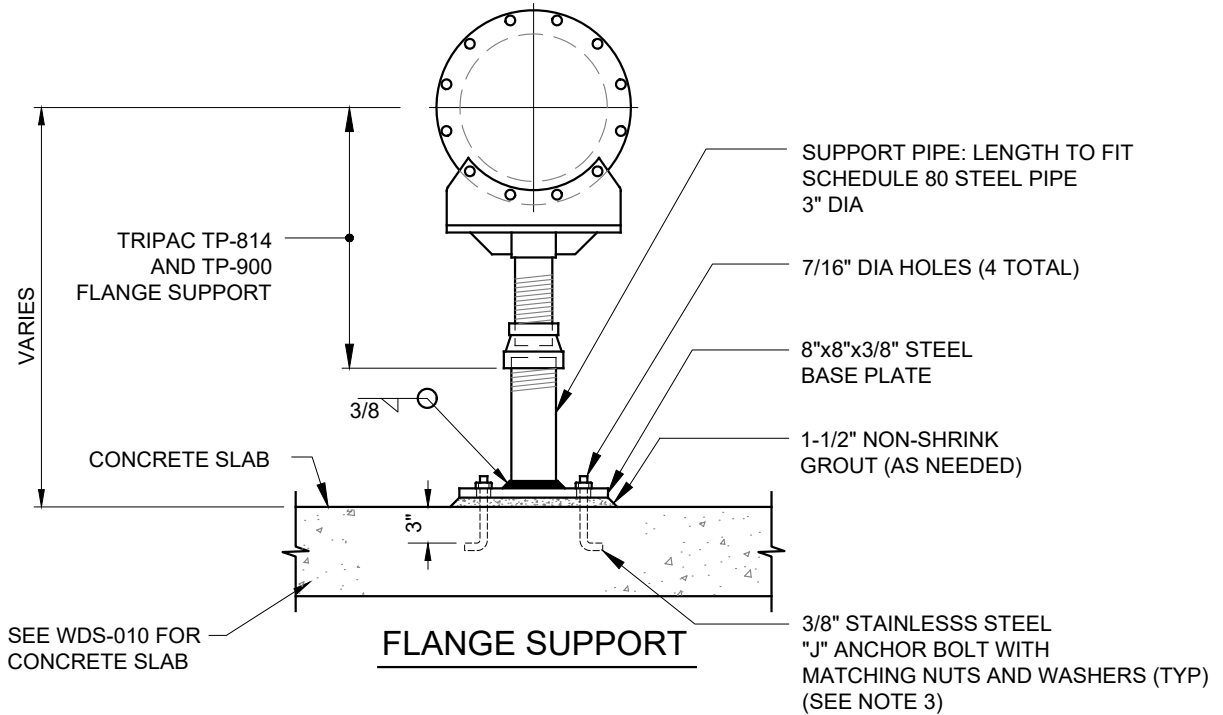

METER SUPPORTS

WDS - 008



Long Beach Water
 Exceptional Water • Exceptional Service

RECOMMENDED

Robert Johnson
 DIRECTOR OF ENGINEERING

APPROVED

Shirley Reed
 DEPUTY GENERAL MANAGER / CHIEF ENGINEER

DATE: 02-2020

SCALE: N.T.S.

SHEET 1 OF 1