

METER COVER

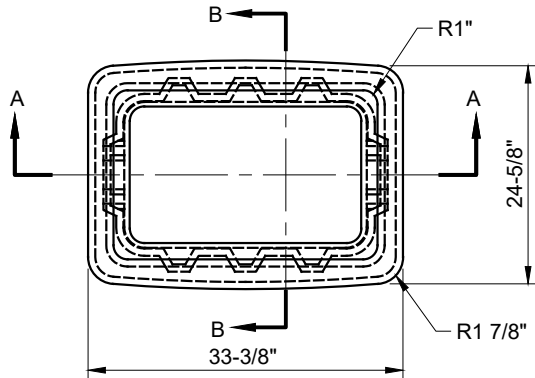

METER BOX TOP VIEW

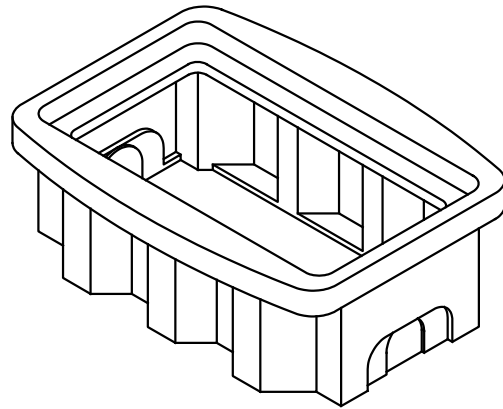

ISOMETRIC VIEW

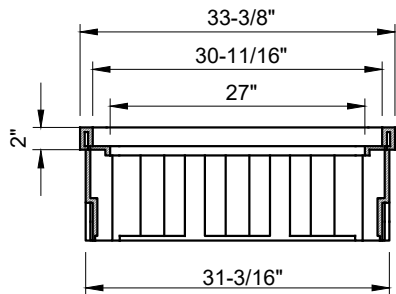

SECTION A-A

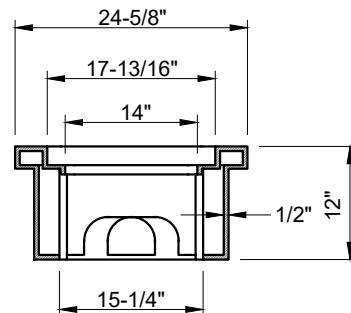

SECTION B-B

METER BOX - 2" AND 1-1/2" SERVICE

METER BOXES

WDS - 009



Long Beach Water
Exceptional Water • Exceptional Service

RECOMMENDED

Robert Johnson

DIRECTOR OF ENGINEERING

APPROVED

Shirley Reed

DEPUTY GENERAL MANAGER / CHIEF ENGINEER

DATE: 02-2020

SCALE: N.T.S.

SHEET 1 OF 2

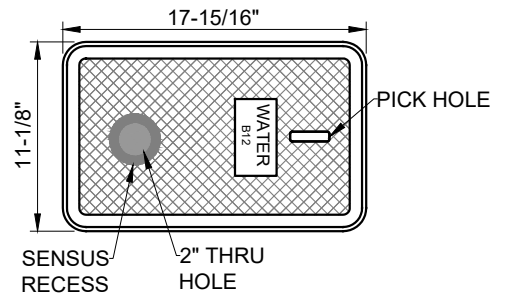

METER COVER

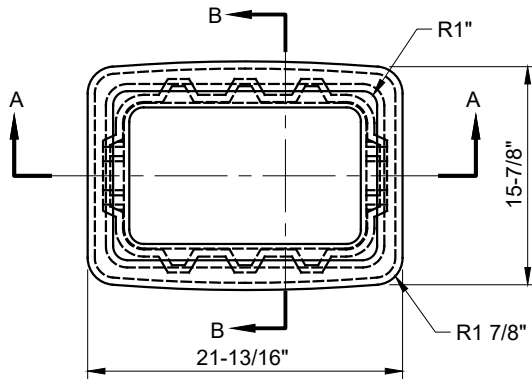

METER BOX TOP VIEW

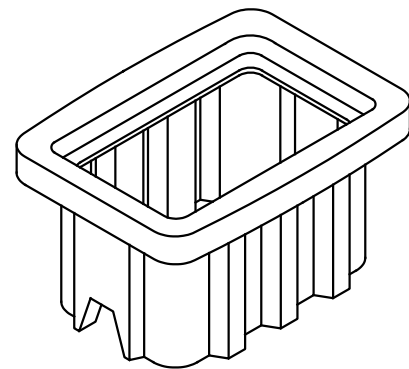

ISOMETRIC VIEW

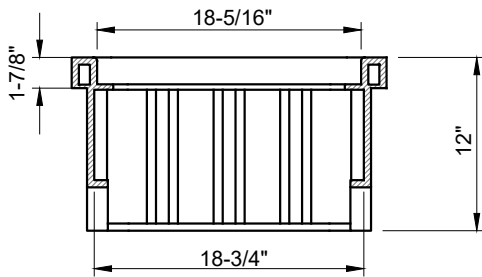

SECTION A-A

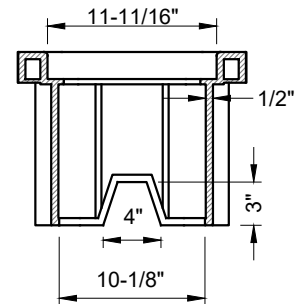

SECTION B-B

METER BOX - 1" AND 3/4" SERVICE

METER BOXES

WDS - 009



Long Beach Water
Exceptional Water • Exceptional Service

RECOMMENDED

Robert Johnson

DIRECTOR OF ENGINEERING

APPROVED

Debra Paul

DEPUTY GENERAL MANAGER / CHIEF ENGINEER

DATE: 02-2020

SCALE: N.T.S.

SHEET 2 OF 2